

## Booster Pump



The Hayward booster pump is exceptionally quiet and uses up to 40% less electricity than other models. Both 1½" pipe unions and ¾" hose fittings are included to provide easy installation and service for new construction and replacement applications. It is also equipped with an elevated base for increased motor ventilation as well as added protection from flooding.





## Booster Pump Features and Benefits

- Exceptionally quiet
- Uses up to 40% less electricity than other booster pumps
- 1½" plumbing union fittings improve performance and allows easy installation and removal
- ¾" hose barb union adapters allow for easy retro fit to existing installations using flexible hose for booster pump connections
- Suitable for all pressure cleaners requiring a booster pump
- Tall mounting base allows for increased motor ventilation as well as protection from flooding
- Volute may be re-oriented in the field for horizontal discharge

MODEL #	TOTAL HORSEPOWER (THP)	RATED HORSEPOWER	VOLTAGE
6060	1.25	0.75	208-230 / 115

Note: Does not include optional 3/4" retrofit hose kit, P/N 6060HKIT

## Dimensions

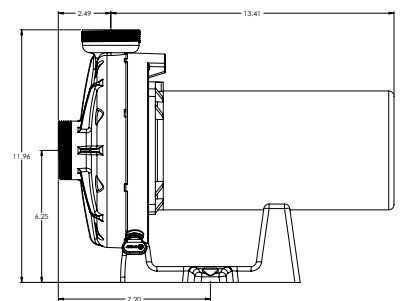
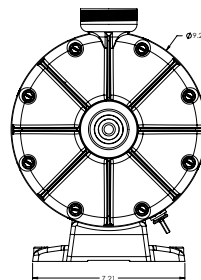

Hayward Booster Pumps are listed by:



To take a closer look at Hayward Pumps, go to [www.haywardpool.com](http://www.haywardpool.com) or call 1-888-HAYWARD.



620 Division Street | Elizabeth, NJ 07201



Hayward is a registered trademark of Hayward Industries, Inc.  
© 2011 Hayward Industries, Inc.